



MDS-T

Medium Tilt Mount



SHIPPING SPECS

Master Carton of 5 units

DIMENSIONS (H X D X W)	9.5" x 19" x 6.75"
WEIGHT	15.65 LBS
UPC	6-93285-00014-0

- Fits 26"-50" screens up to 30 kg/66 lbs.
- Mounts screen 1.77" (45mm) from the wall.
- Tilt adjustable from +5° to -15°, no tools required, just push or pull bottom of screen to desired position.
- Fits VESA 400x400mm, 400x300mm, 400x200mm, 300x300mm, 200x200mm, 200x100mm, 100x100mm.
- Designed for concrete/brick and stud walls.
- Wall bracket designed for extra-secure double-stud mounting.
- Wall bracket dimensions 17.8" (L) x 8.6" (W).
- Includes security screw locking system and bubble level.
- Easy 3-step installation, all mounting hardware included.



BMDA

Basic Dual – Articulated Mount

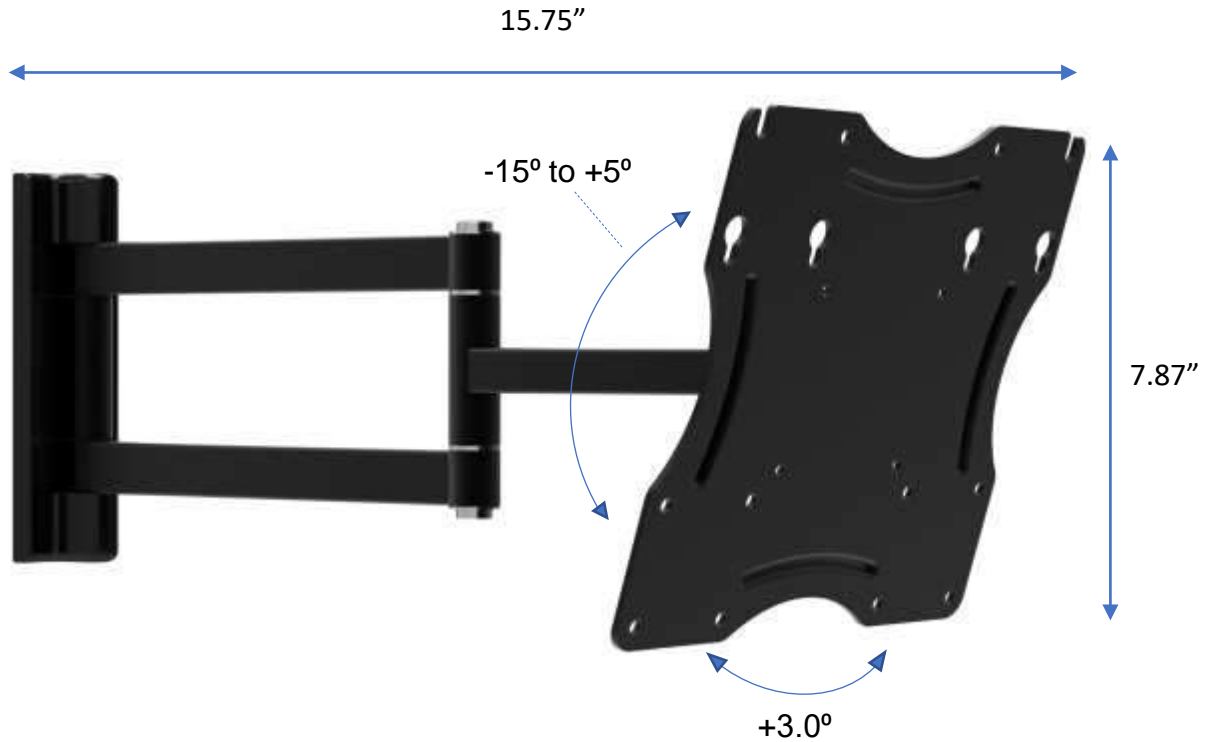

SHIPPING SPECS

Master Carton of 5 units

DIMENSIONS (H X D X W)	9.5" x 12" x 9"
WEIGHT	26.45 LBS
UPC	6-93285-00043-0

- Fits 15"- 32" screens up to 20 kg/44 lbs.
- Fits VESA 75x75mm, 100x100mm 200x100mm 200x200mm.
- Ideal space saver - folds almost flat to wall (35mm/1.38").
- Maximum 400mm/15.7" arm extension allows mounting anywhere, even in or near corners.
- Flexible multi-angle position includes 180° swivel at wall bracket, 180° swivel at centre pivot & 180° swivel at screen.
- Tilt angle -15° to +5°
- Screen level adjustment after installation +3.0°
- Fully assembled for fast easy installation.
- Designed for concrete, brick or stud walls.



MVL

Medium Very Low Profile Mount



SHIPPING SPECS

Master Carton of 4 units

DIMENSIONS (H X D X W)	3.5" x 7.5" x 13"
WEIGHT	15.5 LBS
UPC	6-93285-00013-3

- Fits 26"-47" screens up to 36.4 kg/80 lbs.
- Universal design fits all VESA & non-VESA mounting patterns up to 400x400mm.
- Low profile design mounts screen only 0.47" from wall.
- TV interface arms hook on wall bracket for easy installation.
- Wall bracket dimensions: 17.5" (L) x 3.25" (W).
- Open wall bracket design provides easy cable access & routing.
- Mounts to wood/metal stud or brick/concrete walls.
- Includes full length security bar and extended-length allen key for easy installation.



MVT

Medium Very Low Profile Tilt Mount



SHIPPING SPECS

Master Carton of 4 units

DIMENSIONS (H X D X W)	10.5" x 12" x 8.75"
WEIGHT	32.5 LBS
UPC	6-93285-00039-3

- Fits 26"-47" screens up to 20 kg/44 lbs.
- Fits VESA 400x400mm, 400x300mm, 400x200mm, 300x300mm, 200x200mm, 200x100mm, 100x100mm.
- Ideal space saver - folds 28mm/1.1" from wall.
- Tilt angle -0°/+14°.
- Wall bracket dimensions: 21.5" (L) x 8.9" (W).
- Wall bracket designed for extra-secure double-stud mounting.
- Full length security bar locks screen in place to prevent theft, user may add lock.
- Open wall bracket design provides easy cable access & routing.
- Easy 4-step installation
- All mounting hardware, bubble level & instructions included.
- Mounts to wood/metal stud or brick/concrete walls.



VMDA

Medium Dual-Articulated Mount



SHIPPING SPECS

Master Carton of 6 units

DIMENSIONS (H X D X W)	15" x 16" x 13"
WEIGHT	48 LBS
UPC	6-93285-00015-7

- Fits 26"-55" screens up to 36.4 kg/80 lbs.
- Fits VESA 400x400mm, 400x300mm, 400x200mm, 300x300mm, 200x200mm, 200x100mm, 100x100mm.
- Ideal space saver - folds 55mm/2.17" from wall.
- Maximum 510mm/20" arm extension allows mounting anywhere, even in or near corners.
- Flexible multi-angle position includes 180° swivel at wall bracket, 180° swivel at centre pivot & 180° swivel at screen.
- Tilt angle -15° to +5°.
- Screen level adjustment after installation $\pm 3.5^\circ$.
- Integrated cable management included.



HMDA

Medium Dual-Articulated Mount

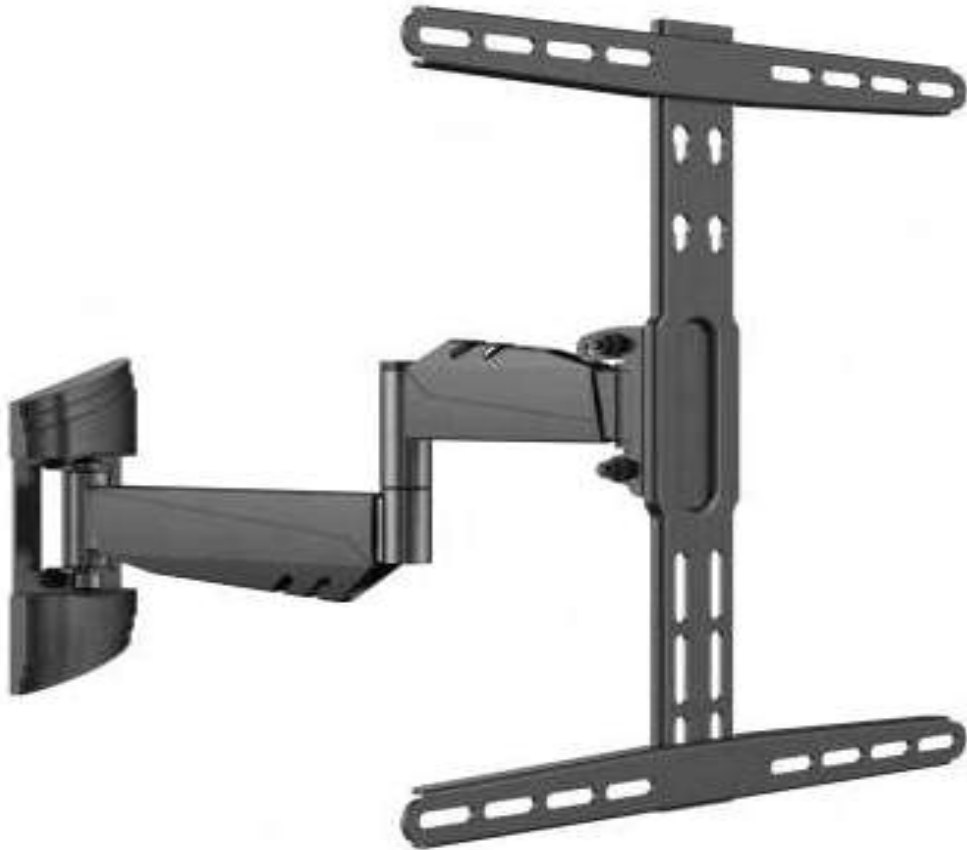

SHIPPING SPECS

Master Carton of 5 units

DIMENSIONS (H X D X W)	10.25" x 20" x 14"
WEIGHT	43.75 LBS
UPC	6-93285-00063-8

- Fits 26"-47" screens up to 25 kg/55 lbs.
- Fits VESA 400x400mm, 400x300mm, 400x200mm, 300x300mm, 200x200mm.
- Ideal space saver - folds 56mm/2.2" from wall.
- Maximum 421mm/16.6" arm extension allows mounting near corners with most screens.
- Flexible multi-angle position includes 180° swivel at wall bracket, 180° swivel at centre pivot & 180° swivel at screen.
- Tilt angle -12° to +2°.
- Screen level adjustment after installation ± 3°.
- Integrated cable management included.



VLTM

Large Flat Panel Tilt Mount



SHIPPING SPECS

Master Carton of 5 units

DIMENSIONS (H X D X W)	9.5" x 27" x 7"
WEIGHT	18.8 LBS
UPC	6-93285-00064-5

- Fits 32"-60" screens up to 35 kg/77 lbs.
- Universal design fits all VESA & non-VESA mounting patterns up to 600x400mm.
- Tilt continuously adjustable from 0° to 10°.
- Flush/tilt design allows use as tilt or low profile mount.
- Very low profile - mounts 0.98" from wall.
- TV interface arms hook on wall bracket for easy installation.
- Wall bracket dimensions: 25.5" (L) x 8.6" (W).
- Wall bracket designed for extra-secure double stud mounting.
- Open wall bracket design provides easy cable access & routing.
- Mounts to wood/metal stud or brick/concrete walls.
- All mounting hardware, bubble level and instructions included.



LTM

Large Flat Panel Tilt Mount



SHIPPING SPECS

Master Carton of 4 units

DIMENSIONS (H X D X W)	8.25" x 37" x 11"
WEIGHT	34 LBS
UPC	6-93285-00019-5

- Fits 42"-90" screens up to 68 kg/150 lbs.
- Universal design fits all VESA & non-VESA mounting patterns up to 800x400mm.
- Tilt continuously adjustable from 0° to 12°.
- Flush/tilt design allows use as tilt or low profile mount.
- TV interface arms hook on wall bracket for easy installation.
- Wall bracket designed for double or triple stud mounting.
- Mounts 2" from wall.
- Wall bracket dimensions: 34.6" (W) x 9.45" (H).
- Open wall bracket design provides easy cable access & routing.
- Mounts to wood/metal stud or brick/concrete walls.
- All mounting hardware & instructions included.



VLDA

Large Double Articulated Mount



SHIPPING SPECS

Master Carton of 4 units

DIMENSIONS (H X D X W)	9.25" x 28.75" x 12"
WEIGHT	50.71 LBS
UPC	6-93285-00050-8

- Fits 42"-70" screens up to 68.2 kg/150 lb.
- Fits VESA 100x100mm, 200x200mm, 400x200mm, 300x300mm, 400x400mm & 600x400mm.
- Maximum 659mm/26" arm extension allows mounting anywhere, even in or near corners.
- Double articulated design for the ultimate in smooth, stable and precise positioning of large flat panels, including easy front-to-back movement.
- Arm can mount in 3 different positions along wall plate for left corner, center wall or right corner mounting.
- Ideal space saver - folds 91mm/3.6" from wall.
- Flexible multi-angle position includes 180° swivel at wall bracket, 180° swivel at centre pivot & 180° swivel at screen.
- Tilt angle -15° to +5°.
- Screen level adjustment after installation + 6°.
- Includes integrated cable management.



VLDC

Large Double Cantilever Mount

The ultimate in viewing, installation and TV hookup flexibility

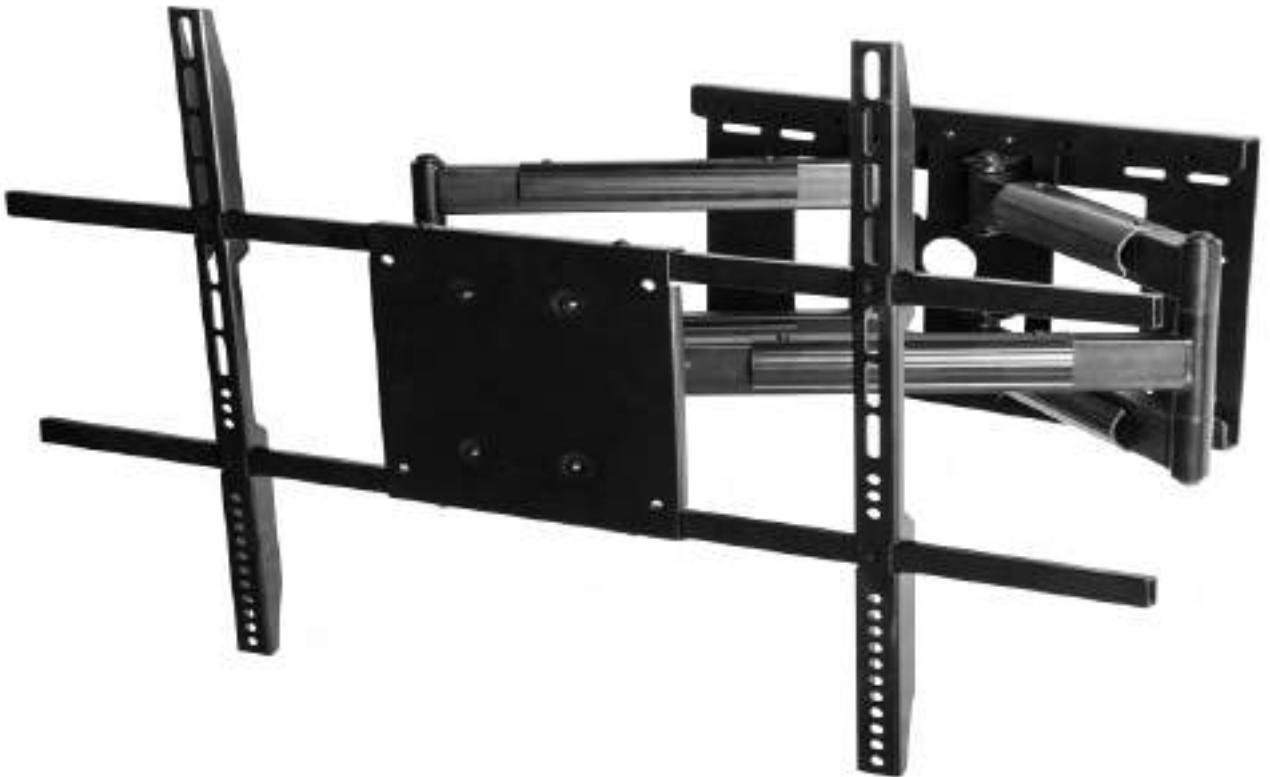

SHIPPING SPECS

DIMENSIONS (H X D X W)	5.5" x 36.5" x 14"
WEIGHT	39.65 LBS
UPC	6-93285-00024-9

- Fits 42"-80" screens up to 90.8 kg/200 lb.
- Fits all VESA mounting patterns from 200x200mm to 800x600mm.
- Maximum 801mm/31.5" arm extension allows mounting anywhere, even in or near corners.
- Double cantilever arms can be mounted in five different positions along wall plate for optimum viewing capability.
- Ideal space saver - folds 110mm/4.34" from wall.
- Flexible multi-angle position includes 180° swivel at wall bracket, 180° swivel at centre pivot & 180° swivel at screen.
- Tilt angle -15° to +5°.
- Screen level adjustment after installation +6°.
- Heavy duty steel construction, easy installation, bilingual packaging, attractive black finish.
- Fully assembled for fast easy installation.



LCM

Large Flat Panel Ceiling Mount



SHIPPING SPECS

Master Carton of 2 units

DIMENSIONS (H X D X W)	9.25" x 35.5" x 12.25"
WEIGHT	40.90 LBS
UPC	6-93285-00023-2

- Fits 32"-60" screens up to 56.7 kg./125 lb.
- Adjustable drop from 95cm/37.5" to 152cm/60".
- Universal design fits all VESA & non-VESA mounting patterns up to 700 x 500mm.
- Ceiling bracket tilts up to 90° for flat or sloped ceiling mounting or wall mounting.
- Screen can swivel up to 60° left or right.
- Tilt continuously adjustable from 0° to 12°.
- Screen leveling adjustment after installation ± 2.5°.
- Heavy duty construction, easy installation, bilingual packaging, attractive black finish.



MVWM

Multi-Screen Video Wall Mount



SHIPPING SPECS

Master Carton of 2 units

DIMENSIONS (H X D X W)	4" x 25.5" x 23.5"
WEIGHT	33.65 LBS
UPC	6-93285-00081-2

- Fits 37" - 70" screens up to 50 kg/110 lb.
- Fits all VESA patterns 100x100mm to 600x400mm.
- Push in/ pop out quick release design including 10° upward tilt function for easy access, service, and installation. Depth from wall 4.5" to 12.2".
- Modular design with unlimited multiscreen configurations possible.
- Screens may be mounted in portrait or landscape orientation.
- 8-point micro adjustment for seamless display alignment.
- Ideal for recessed applications.
- UL approved for use in Canada and USA.
- Integrated cable management.
- Security screws and add-on lock feature for safety and security



BT77

B-Tech Ultra Grip Pro Speaker Mounts



BT77 SHIPPING SPECS

Master Carton of 4 units

DIMENSIONS (H X D X W)	9" x 12" x 12"
WEIGHT	26.85 LBS
UPC	5-19318-04770-1

- **HEAVY DUTY:** Designed for bookshelf speakers weighing up to 55lbs
- **ADJUSTABLE:** clamp fits speakers from 135mm (5.3") to 280mm (11") wide.
- **PRECISE POSITIONING:** Tilt 7° up or down and swivel up to 180° for perfect speaker placement and acoustics.
- **EASY INSTALLATION WITH MOUNTING HARDWARE INCLUDED:** Includes hardware necessary to easily mount into stud/concrete/brick/stone walls. Wall cover included for professional looking installation.



BT8310

Professional Video Wall Mount with Quick Lock Push System



BT8310 SHIPPING SPECS

DIMENSIONS (H X D X W)	5.75" x 24.5" x 24.25"
WEIGHT	31.50 LBS
UPC	5-019319-079985

- Modular mount for unlimited wall display configurations
- Suitable for landscape or portrait screen mounting
- Push to open / push to close system provides quick and easy service access
- Tool-less micro-adjustments at 8 points for seamless display alignment
- Suitable for both wall or pole mounting
- Integrated cable management
- Perfect solution for mounting screens into a recessed wall
- Safety screws help prevent unauthorised removal of screens
- Includes Interface Adaptor Arms as standard (pictured below) for use with screen with VESA 600 x 400 fixings
- All mounting hardware included



BSTC

Basic TV Cart

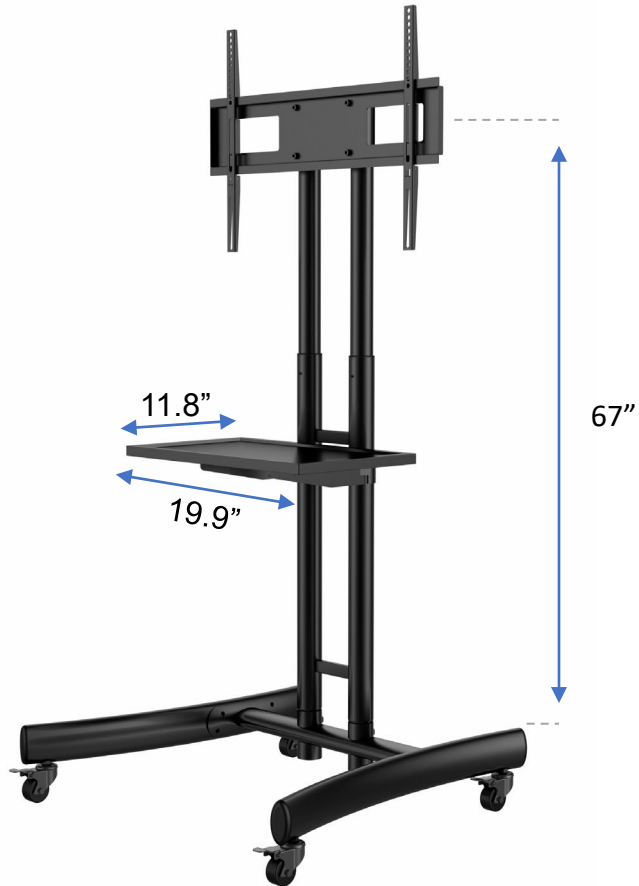

BSTC SHIPPING SPECS

CARTON DIMENSIONS (H X D X W)	8.75" x 38" x 13"
WEIGHT	42 LBS
UPC	6-93285-00033-1

- **UNIVERSAL TV INTERFACE:** mount will hold up to a 61" TV (up to 600 x 400mm VESA and 100 lbs.) to make this the ideal choice for any size conference room or living room.
- **HEAVY DUTY:** Metal casters feature 4 large commercial grade locking 2.5" rubber wheels. Rolls effortlessly, locks securely in place.
- **SHELF INCLUDED:** 19.9" x 11.8" height-adjustable metal shelf to hold DVR or other electronic accessories (up to 10 lbs.).
- **TELESCOPIC POLES:** allow for flexible height adjustment up to 67" to top of tv mount. Integrated cable management system for neat installation.
- **STABLE:** Sturdy heavy duty design and wide base offers stability when mobile or stationary .



VSTC

Standard TV Cart

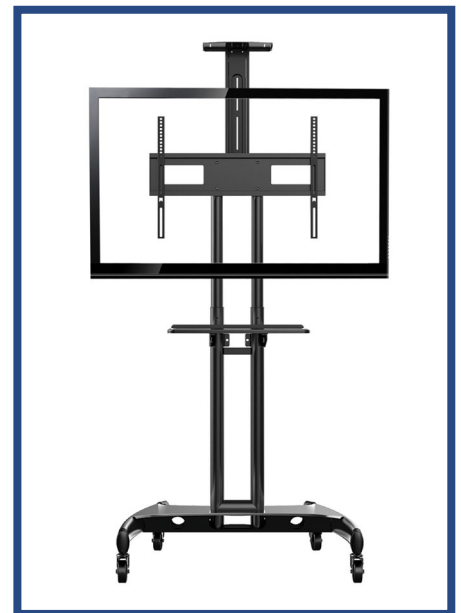
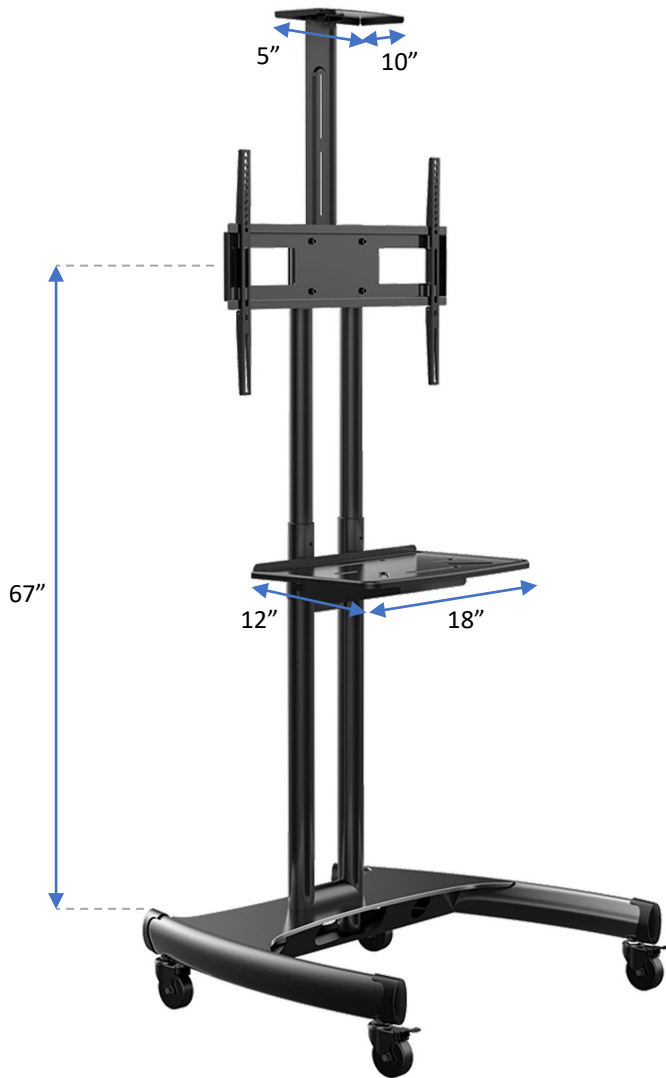

VSTC SHIPPING SPECS

CARTON DIMENSIONS (H X D X W)	20" x 25.5" x 15.5"
WEIGHT	51.3 LBS
UPC	6-93285-00030-0

- Fits flat panel screens from 32" to 70"/100 lbs. in standard horizontal (landscape) orientation.
- Universal design fits all VESA & non-VESA mounting patterns up to 600x400mm.
- A/V component shelf (18" w x 12" d) & top mount webcam shelf (10" w x 5" d) included, load rating 10 lbs. per shelf.
- Telescopic height adjustment 41.3" to 59" from top of base (base dimensions 32" w x 28" d).
- Average height to top of TV 67"/170cm depending on screen size being mounted.
- Integrated cable management included.
- 2.5" commercial grade rubberized braked castors included - rolls effortlessly, locks securely in place.



FPM

Flush Projector Mount



FPM SHIPPING SPECS

Master Carton of 8 units

DIMENSIONS (H X D X W)	11.75" x 13.25" x 13.5"
WEIGHT	33.55 LBS
UPC	6-93285-00021-8

- Supports LCD/DLP projectors up to 25 kg/55 lb.
- Flush mounting only 13.5cm (5.3") from ceiling.
- Pitch (tilt) 0-20° up or down.
- Roll (swivel) 0-20° side to side.
- Rotates up to 360°.
- Advanced ball joint design allows you to adjust & lock projector position instantly.
- Universal design accepts projector mounting holes spacing from 80mm (3.2") to 500mm (19.6").
- Heavy duty construction, easy installation, bilingual packaging, attractive black finish.



TPM

Telescopic Projector Mount



TPM SHIPPING SPECS

Master Carton of 4 units

DIMENSIONS (H X D X W)	8" x 25" x 15.5"
WEIGHT	33.60 LBS
UPC	6-93285-00022-5

- Fits all LCD/DLP projectors up to 30 kg/66 lb.
- Adjustable drop from 670mm/26.4" to 900mm/35.44".
- Ceiling bracket tilts up to 90° for flat or sloped ceiling mounting, or wall mounting.
- Pitch (tilt) 0-20° up or down.
- Roll (swivel) 0-20° side to side.
- Rotates up to 360°.
- Advanced ball joint design allows you to adjust & lock projector position instantly.
- Universal design accepts projector mounting holes spacing from 180mm (7") to 400mm (15.75").
- Heavy duty construction, easy installation, bilingual packaging, attractive black finish.



18U Rack with LCD Control Panel



18U RACK SHIPPING SPECS

DIMENSIONS (H X D X W)	5.50" x 24.50" x 24.50"
WEIGHT	40.30 LBS
UPC	6-93285-00052-2

- Now with LCD Thermostat Control Panel to automatically set cooling fan start and stop temperature.
- Conforms to all industry standards for 19" audio/video & server racks in 600x600mm configuration.
- Supplied in 3 cartons as flat packed kit to save on freight and storage, which also makes it easier to move to installation location and assemble on site.
- Assembled dimensions HWD 39.4" x 23.6" x 23.6". Max. load capacity 600 kg/1320 lbs.
- Complete rack includes frame, all vertical & horizontal rails, front glass door, rear metal door, 2 side panels, 4 braked castors, 2 locks w/2 keys, 2 UL listed fans, assembly hardware & instructions (assembly instructions also on www.rocelco.com.) Shelves not included.
- Racks available fully assembled at extra cost.
- Available shelves include 2U 16", 2U 18", 5U 20".
- Other available accessories include 2U blank panels, Rocelco PDU (8-outlet power strip for racks) & Rocelco RCM (rack cable manager).



27U Rack with LCD Control Panel



27U RACK SHIPPING SPECS

DIMENSIONS (H X D X W)	5.50" x 24.50" x 24.50"
WEIGHT	40.35 LBS
UPC	6-93285-00053-9

- Now with LCD Thermostat Control Panel to automatically set cooling fan start and stop temperature.
- Conforms to all industry standards for 19" audio/video & server racks in 600x600mm configuration.
- Supplied in 3 cartons as flat packed kit to save on freight and storage, which also makes it easier to move to installation location and assemble on site.
- Assembled dimensions HWD 55.1" x 23.6" x 23.6". Max. load capacity 600 kg/1320 lbs.
- Complete rack includes frame, all vertical & horizontal rails, front glass door, rear metal door, 2 side panels, 4 braked castors, 2 locks w/2 keys, 2 UL listed fans, assembly hardware & instructions (assembly instructions also on www.rocelco.com). Shelves not included.
- Racks available fully assembled at extra cost.
- Available shelves include 2U 16", 2U 18", 5U 20".
- Other available accessories include 2U blank panels, Rocelco PDU (8-outlet power strip for racks) & Rocelco RCM (rack cable manager).



LCD Rack Accessories



ROCELCO 2U 16" SHELF

DESCRIPTION	DIMENSIONS	WEIGHT
Vented 2U shelf 16" deep mounting hardware included load capacity 20 kg	20" x 17" x 5"	4 LBS



ROCELCO 2U 18" SHELF

DESCRIPTION	DIMENSIONS	WEIGHT
Vented 2U shelf 18" deep mounting hardware included load capacity 20 kg	20" x 9" x 4"	6 LBS



ROCELCO 5U 20" SHELF

DESCRIPTION	DIMENSIONS	WEIGHT
Vented 5U shelf 20" deep mounting hardware included load capacity 60 kg	21" x 20" x 10"	11 LBS



ROCELCO 2U BLANK

DESCRIPTION	DIMENSIONS	WEIGHT
Blank panel 2U high	20" x 4" x 1"	1 LBS



ROCELCO PDU

DESCRIPTION	DIMENSIONS	WEIGHT
8-outlet surge protected power strip for racks	20" x 3" x 4"	1.85 LBS



ROCELCO CAGE NUTS

DESCRIPTION	DIMENSIONS	WEIGHT
50-pack spare cage nut set with bolts	N/A	1 LBS

ROCELCO RCM

DESCRIPTION	DIMENSIONS	WEIGHT
Rack cable manager	N/A	1 LBS